

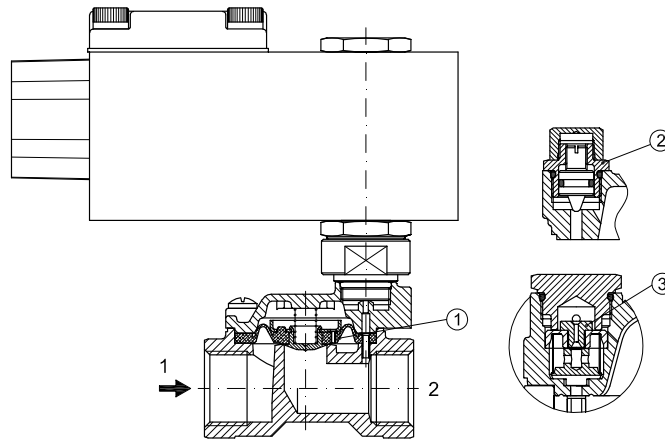

COILS Code ②	Alternating Current 50/60Hz				Direct Current			Electrical connection
	24V	48V	110V	220V 230V	12V	24V	48V	
Series 6	A6B	A6C	A6D	A6E	A60	A61	A62	1/2" NPT

**DESCRIPTION**  
 Voltage tolerance  $\pm 10\%$   
 Protection class IP66  
 Continuous service ED100%



**OVERALL DIMENSIONS**  
mm

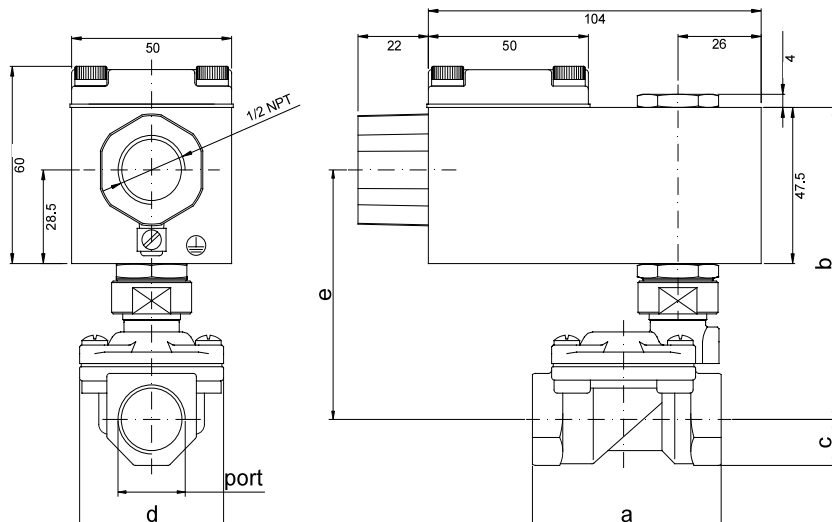

PORT SIZE	a	b	c	d	e	weight
3/8	59	95	14	45	76	0.92
1/2	59	95	14	45	76	0.92
3/4	79	105	18	54	82	1.10
1	96	113	20	72	91	1.50